

***Owner's Guide
and
Installation Instructions***



***Rheem Pronto
Instantaneous Gas Water Heater
834 Series
012, 016 Models***



*This water heater must be installed and serviced by a qualified person.
Please leave this guide with the householder.*

⚠ Warning: Upon completion of the installation and commissioning of the water heater, leave this guide with the householder or a responsible officer. **DO NOT** leave this guide inside of the cover of the water heater, as it may interfere with the safe operation of the water heater or ignite when the water heater is turned on.

An electronic copy of these Owner's Guide and Installation Instructions can be downloaded from rheem.com.au.

PATENTS

This water heater may be protected by one or more patents or registered designs in the name of Rheem Australia Pty Ltd or Paloma Co., Ltd.

TRADEMARKS

® Registered trademark of Rheem Australia Pty Ltd.
™ Trademark of Rheem Australia Pty Ltd.

Note: Every care has been taken to ensure accuracy in preparation of this publication. No liability can be accepted for any consequences, which may arise as a result of its application.

CONTENTS

HOUSEHOLDER

This booklet contains important information about your new water heater, including terms of the Rheem warranty.

We recommend you read pages 7 to 16,
and the terms of the Rheem warranty on pages 4 to 6.

The other pages are intended for the installer but may be of interest.

Warranty	4
Safety, Warnings, Installation Notes	7
About Your Water Heater	9
Water Supplies.....	14
Save A Service Call	15
Installation – Water Heater	17
Connections – Plumbing	23
Wiring Diagram	25
Commissioning.....	26
Draining The Water Heater	30

RHEEM AUSTRALIA PTY LTD, A.B.N. 21 098 823 511, www.rheem.com.au
For Service Telephone 131 031 AUSTRALIA

RHEEM INSTANTANEOUS GAS WATER HEATER WARRANTY – AUSTRALIA ONLY

INSTANTANEOUS GAS WATER HEATERS 834 SERIES 012, 016 MODELS

1. THE RHEEM WARRANTY – GENERAL

- 1.1 This warranty is given by Rheem Australia Pty Limited ABN 21 098 823 511 of 1 Alan Street, Rydalmere New South Wales, the supplier of Rheem instantaneous gas water heaters.
- 1.2 Rheem offer a trained and qualified national service network who will repair or replace components at the address of the water heater subject to the terms of the Rheem warranty. Rheem Service, in addition can provide preventative maintenance and advice on the operation of your water heater. The Rheem Service contact number is 131031, with Contact Centre personnel available 24 hours, 7 days a week to take your call and if necessary to arrange a service call for during normal working hours Monday to Friday (hours subject to change).
- 1.3 For details about this warranty, you can contact us on 131031 or by email at warrantyenquiry@rheem.com.au (not for service bookings).
- 1.4 The terms of this warranty and what is covered by it are set out in sections 2 and 3 and apply to water heaters manufactured after 1st March 2015.
- 1.5 If a subsequent version of this warranty is published, the terms of that warranty and what is covered by it will apply to water heaters manufactured after the date specified in the subsequent version.

2. TERMS OF THE RHEEM WARRANTY AND EXCLUSIONS TO IT

- 2.1 The decision of whether to repair or replace a faulty component is at Rheem's sole discretion.
- 2.2 If you require a call out and we find that the fault is not covered by the Rheem warranty, you are responsible for our standard call out charge. If you wish to have the relevant component repaired or replaced by Rheem, that service will be at your cost.
- 2.3 Where a failed component or heat exchanger is replaced under this warranty, the balance of the original warranty period will remain effective. The replacement does not carry a new Rheem warranty.
- 2.4 Where the water heater is installed outside the boundaries of a metropolitan area as defined by Rheem or further than 25 km from either a regional Rheem branch office or an Accredited Rheem Service Agent's office, the cost of transport, insurance and travelling between the nearest branch office or Rheem Accredited Service Agent's office and the installed site shall be the owner's responsibility.
- 2.5 Where the water heater is installed in a position that does not allow safe or ready access, the cost of that access, including the cost of additional materials handling and/or safety equipment, shall be the owner's responsibility. In other words, the cost of dismantling or removing cupboards, doors or walls and the cost of any special equipment to bring the water heater to floor or ground level or to a serviceable position is not covered by this warranty.
- 2.6 This warranty only applies to the original and genuine Rheem water heater in its original installed location and any genuine Rheem replacement parts.
- 2.7 The Rheem warranty does not cover faults that are a result of:
 - a) Accidental damage to the water heater or any component (for example: (i) Acts of God such as floods, storms, fires, lightning strikes and the like; and (ii) third party acts or omissions).
 - b) Misuse or abnormal use of the water heater.
 - c) Installation not in accordance with the Owner's Guide and Installation Instructions or with relevant statutory and local requirements in the State or Territory in which the water heater is installed.
 - d) Connection at any time to a water supply that does not comply with the water supply guidelines as outlined in the Owner's Guide and Installation Instructions.

RHEEM INSTANTANEOUS GAS WATER HEATER WARRANTY – AUSTRALIA ONLY

INSTANTANEOUS GAS WATER HEATERS 834 SERIES 012, 016 MODELS

- e) Repairs, attempts to repair or modifications to the water heater by a person other than Rheem Service or a Rheem Accredited Service Agent.
 - f) Faulty plumbing or faulty gas or power supply.
 - g) Failure to maintain the water heater in accordance with the Owner's Guide and Installation Instructions.
 - h) Transport damage.
 - i) Fair wear and tear from adverse conditions (for example, corrosion).
 - j) Cosmetic defects.
 - k) Ice formation in the waterways of a water heater.
- 2.8 Subject to any statutory provisions to the contrary, this warranty excludes any and all claims for damage to furniture, carpet, walls, foundations or any other consequential loss either directly or indirectly due to leakage from the water heater, or due to leakage from fittings and/ or pipe work of metal, plastic or other materials caused by water temperature, workmanship or other modes of failure.
- 2.9 If the water heater is not sized to supply the hot water demand in accordance with the guidelines in Rheem's water heater literature, any resultant fault will not be covered by the Rheem warranty.

3. WHAT IS COVERED BY THE RHEEM WARRANTY FOR THE WATER HEATERS DETAILED IN THIS DOCUMENT

- 3.1 Rheem will repair or replace a faulty component of your water heater if it fails to operate in accordance with its specifications as follows:

What components are covered	The period from the date of installation in which the fault must appear in order to be covered	What coverage you receive
All components (all installations)	Year 1	Repair and/or replacement of the faulty component, free of charge, including labour.
All components (only if the water heater is installed in a single-family domestic dwelling)	Years 2 & 3	Repair and/or replacement of the faulty component, free of charge, including labour.
The heat exchanger (only if the water heater is installed in a single-family domestic dwelling)	Years 4 to 10	Replacement heat exchanger, free of charge. Installation and repair labour costs are the responsibility of the owner.

RHEEM INSTANTANEOUS GAS WATER HEATER WARRANTY – AUSTRALIA ONLY

INSTANTANEOUS GAS WATER HEATERS 834 SERIES 012, 016 MODELS

4. ENTITLEMENT TO MAKE A CLAIM UNDER THIS WARRANTY

- 4.1 To be entitled to make a claim under this warranty you need to:
- a) Be the owner of the water heater or have consent of the owner to act on their behalf.
 - b) Contact Rheem Service without undue delay after detection of the defect and, in any event, within the applicable warranty period.
- 4.2 You are **not** entitled to make a claim under this warranty if your water heater:
- a) Does not have its original serial numbers or rating labels.
 - b) Is not installed in Australia.

5. HOW TO MAKE A CLAIM UNDER THIS WARRANTY

- 5.1 If you wish to make a claim under this warranty, you need to:
- a) Contact Rheem on 131031 and provide owner's details, address of the water heater, a contact number and date of installation of the water heater or if that's unavailable, the date of manufacture and serial number (from the rating label on the water heater).
 - b) Rheem will arrange for the water heater to be tested and assessed on-site.
 - c) If Rheem determines that you have a valid warranty claim, Rheem will repair or replace the water heater in accordance with this warranty.
- 5.2 Any expenses incurred in the making of a claim under this warranty will be borne by you.

6. THE AUSTRALIAN CONSUMER LAW

- 6.1 Our goods come with guarantees that cannot be excluded under the Australian Consumer Law. You are entitled to a replacement or refund for a major failure and for compensation for any other reasonably foreseeable loss or damage. You are also entitled to have the goods repaired or replaced if the goods fail to be of acceptable quality and the failure does not amount to a major failure.
- 6.2 The Rheem warranty (set out above) is in addition to any rights and remedies that you may have under the Australian Consumer Law.

SAFETY, WARNINGS, INSTALLATION NOTES

It is important you read the following safety and warnings information.

⚠ SAFETY AND WARNINGS

- This water heater is only intended to be operated by persons who have the experience or the knowledge and the capabilities to do so.
- This water heater is not intended to be operated by persons with reduced physical, sensory or mental capabilities i.e. the infirm, or by children. Children should be supervised to ensure they do not interfere with the water heater.
- This water heater is supplied with a temperature sensor, over-temperature cut-off device and a pressure relief valve. These devices must not be tampered with or removed. The water heater must not be operated unless each of these devices is fitted and is in working order.

The Rheem warranty may not cover faults if safety devices or the relief valve are tampered with or if the installation is not in accordance with these instructions.

- This water heater is not suitable for pool heating, or as part of hot water circulation flow and return system, or as an in-series booster for a solar water heater, and **MUST NOT** be used for these applications.
- For continued safety of this water heater it must be installed, operated and maintained in accordance with the Owner's Guide and Installation Instructions.
- Servicing of the water heater must only be carried out by qualified personnel. Phone Rheem Service or their nearest Accredited Service Agent / Centre.
- Do not modify this water heater.
- Close the cold water isolation valve to the water heater prior to performing general maintenance. This will prevent the water heater from being used while you clean or spray around the water heater.

Refer to "[General Maintenance](#)" on page 11 for additional information.

- Do not spray **aerosols** in the vicinity of this water heater while it is in operation. Propellants and gases in many aerosol sprays contain hydrocarbons which are flammable. Gases from aerosol sprays may also become corrosive when drawn into a flame.
- Do not use or store **flammable materials** in or near this water heater. Flammable liquids (such as petrol), combustible materials (such as newspapers) and similar articles must be kept well away from the water heater and the flue terminal.
- Do not store **swimming pool chemicals, household cleaners, etc.**, near the water heater.
- Do not place articles on or against this water heater, or in contact with the flue terminal. Ensure the flue terminal is not obstructed in any way at any time.
- Do not use Propane / Butane gas mixtures in a Propane model. A Propane model is designed to operate on Propane only. The use of Propane / Butane mixture, such as automotive LP gas fuel, in a Propane model is unsafe and can cause damage to the water heater.
- The water heater is not fitted with a frost protection system. If there is a risk of freezing, then it is necessary to drain the water heater.

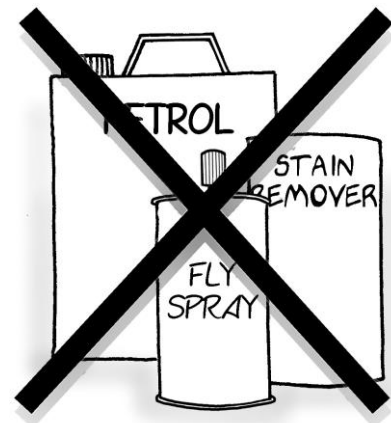

Refer to "[No Frost Protection](#)" on page 10 and to "[Draining the Water Heater](#)" on page 12.

INSTALLATION NOTES

This water heater must be installed:

- by a qualified person,
- in accordance with the installation instructions,
- in compliance with the Plumbing Code of Australia (PCA) and Plumbing Standard AS/NZS 3500.4,
 - This water heater is designed for outdoor installation only.
 - This water heater is intended to be permanently connected to the water mains and not connected by a hose-set. A braided flexible hose or semi-flexible connector may be used for connection to the water heater, where permitted by AS/NZS 3500.4.
- in compliance with the Gas Installations Standard AS/NZS 5601.1,
- in compliance with all local codes and regulatory authority requirements.

Installation and commissioning requirements and details for the installing plumber are contained on [pages 17 to 30](#).

Mains pressure water supply

The water heater is designed to operate at mains pressure by connecting directly to the mains water supply.

The maximum mains water supply pressure for the water heater is 1,000 kPa. If the mains supply pressure in your area exceeds 1,000 kPa, an approved pressure limiting valve that does not have non-return valve characteristics (such as an RMC PSL series valve) must be installed.

A minimum water supply pressure of 120 kPa (for an 834012 model) or 140 kPa (for an 834016 model) is required, i.e. whilst water is flowing through the water heater, to achieve the rated flow and performance of the water heater.

Refer to [“Mains Water Supply”](#) on page 18 for additional information.

Mounting of the water heater

This water heater must be installed vertically upright with the water and gas connections on the underside, pointing toward the ground. The back of the water heater can be either against a wall or supported by a frame. The water heater must be well secured to the wall or frame using two fasteners at the top and one fastener at the bottom of the unit, suitable for the wall or frame type. Refer to the [note](#) on page 17 for additional information.

ABOUT YOUR WATER HEATER

WATER HEATER APPLICATION

This water heater is designed for use in a single family domestic dwelling for the purpose of heating potable water. Its use in an application other than this may shorten its life.

This water heater is not suitable for pool heating, or as part of hot water circulation flow and return system, or as an in-series booster for a solar water heater, and **MUST NOT** be used for these applications.

MODEL TYPE

The Rheem® instantaneous gas water heater model you have chosen is for outdoor installation only. This model has a manufacturer's warranty (refer to [the Rheem warranty](#) on page 4).

The water heater has a maximum preset outlet temperature setting of 60°C.

This 834 series water heater is fitted with:

- A hydro-electric generator which provides power to operate the electronic system. An external electrical power source is not required.
- Electronic ignition
- Electronic temperature control
- Manual seasonal water flow adjustment valve as a supplementary control to compensate for seasonal variations in mains water supply temperature
- Cold start-up energy saving and water saving functions
- Electronic overheat protection
- Over-temperature cut-off device
- Inlet water strainer
- Overpressure relief valve
- Self-diagnosis function.

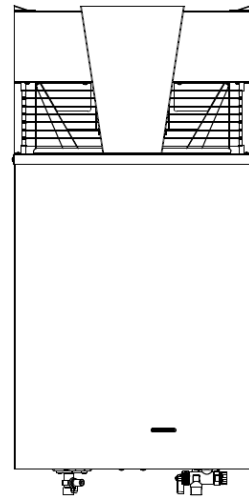

WATER HEATER OPERATION

The water heater operates automatically, heating water as it passes through the water heater. When a hot tap is opened, the gas burners ignite to provide immediate heating of the water. A “green” LED will illuminate when the water heater is operating. The heat produced by the burner is transferred to the water through the heat exchanger. The water is heated to the preset outlet temperature by the automatic adjustment of the gas supply to the burner to suit the water flow rate. The gas burners extinguish when the hot tap is closed. Automatic safety controls are fitted to the water heater to provide safe and efficient operation.

Notes

- For areas that may experience very cold mains water temperature in winter, it may be necessary to set the seasonal water flow adjustment valve (located at the underside of the water heater) to the “Winter” position to reduce the risk of insufficient heating of the water. Reset the seasonal water flow adjustment valve to the “Summer” or another intermediate position as the mains water supply becomes warmer.
- It is recommended to use water saving shower heads and tap ware with this water heater. This will not only reduce water usage, but also assist with temperature control in winter and temperature fluctuation caused by simultaneous water draw off from other taps.
- For areas with a lower mains water pressure supply, it is advisable to set the seasonal water flow adjustment valve to the “Summer” position only. This will minimise water flow restriction through the water heater.

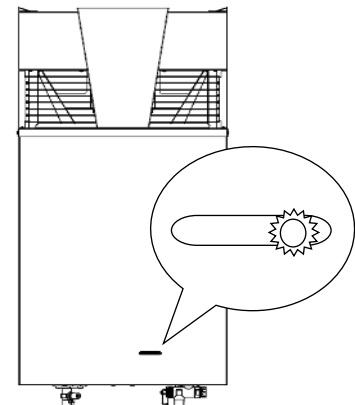

green LED illuminates when heating

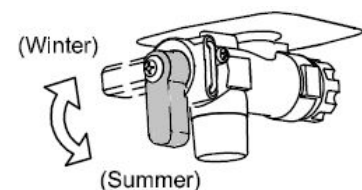

water flow adjustment valve
(manual seasonal adjustment)

HOW HOT SHOULD THE WATER BE?

The water heater heats the water to the preset outlet temperature setting. The factory preset outlet temperature setting of the 834 series water heater is 60°C.

Note: The preset outlet temperature setting of this water heater cannot be adjusted by the householder. The setting can only be adjusted by the installer, Rheem Service or their nearest Accredited Service Agent.

HOTTER WATER INCREASES THE RISK OF SCALD INJURY

An 834 series water heater can deliver hot water at temperatures up to 60°C, which can cause scalding. Water at this temperature may have been plumbed to fixtures where water hotter than 50°C is allowed, such as the kitchen and laundry.

Check the water temperature before use, such as when entering a shower or filling a bath or basin, to ensure it is suitable for the application and will not cause scald injury.

We recommend and it may be required by regulations that an approved temperature limiting device be fitted into the hot water piping to the bathroom and ensuite when an 834 series water heater is installed. This will keep the water temperature below 50°C at the bathroom and ensuite. The risk of scald injury will be reduced and if the preset outlet temperature setting has not been adjusted below 60°C, still allow hotter water to the kitchen and laundry.

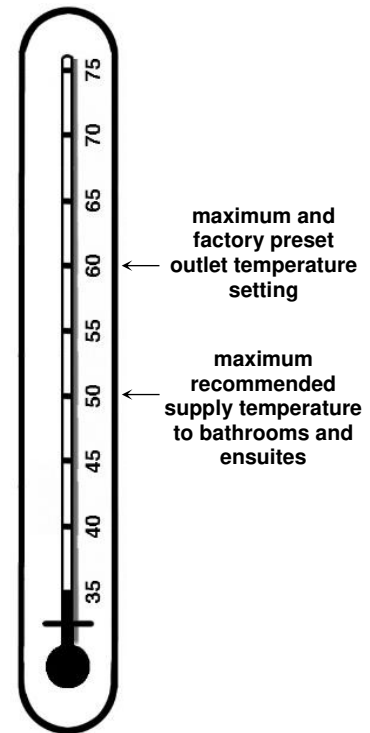

REDUCED HOT WATER FLOW WHEN HEAT EXCHANGER IS COLD

At a cold start-up, i.e. when the water heater has not operated for some time (which is most often first thing in the morning), the initial flow of hot water may be reduced for a period of 5-10 seconds while the heat exchanger warms up. **This is both an energy and water saving feature of this water heater.** Once the heat exchanger has warmed up the hot water flow will increase and remain at normal flow levels. This feature will only occur at a cold start-up and not when the heat exchanger is already warm from a recent use of hot water.

NO FROST PROTECTION

The water heater is **NOT** fitted with a frost protection system. If there is a risk of freezing, then it is necessary to drain the water heater. Refer to [“Draining the Water Heater”](#) on page 12.

Notes

- Damage caused by freezing is not covered by the Rheem warranty. Refer to [“Terms of the Rheem Warranty”](#) on page 4.
- Pipe work to and from the water heater must be adequately insulated to prevent freezing.

PRECAUTIONS

The water heater must be maintained in accordance with the Owner’s Guide and Installation Instructions. Refer to [“General Maintenance”](#) on page 11 and [“Major Service Every Five Years”](#) on page 11.

If this water heater is to be used where an uninterrupted hot water supply is necessary for your application or business you should ensure that you have back-up redundancy within the hot water system design. This should ensure the continuity of hot water supply in the event that this water heater were to become inoperable for any reason. We recommend you seek advice from a plumber or specifier about your needs and building back-up redundancy into your hot water supply system.

GENERAL MAINTENANCE

General maintenance can be performed by the dwelling occupant. It is recommended general maintenance be conducted every six (6) months or more regularly as required.

Close the cold water isolation valve to the water heater prior to performing general maintenance. This will prevent the water heater from being used while you clean or spray around the water heater. Open the cold water isolation valve when finished performing the general maintenance.

The general maintenance includes:

- The jacket of the water heater can be cleaned with a soft cloth and warm mild soapy water if required. Under no circumstances should abrasive materials or powders be used.
- Inspect around the air inlet, flue terminal and the water heater in general for plant growth.
 - Trim back any shrubs, bushes or other plants which have encroached around the water heater.

Plant growth across the air inlet and flue terminal can interfere with the performance of the water heater.

- Inspect around the water heater for infestations of insects, such as ants. Insects encroaching into or nesting in the water heater can interfere with the operation of the water heater and also damage components. The area around the water heater can be sprayed with insecticide to rid the area of insects.

⚠ Warning: Do not spray insecticide near the water heater while it is operating. Propellants in many insect sprays contain hydrocarbons which are flammable. Gases from aerosol sprays may also become corrosive when drawn into a flame.

- If necessary to rid the area of insects:
 - Ensure the cold water isolation valve at the inlet to the water heater has been closed.
 - Spray the affected area, taking care not to spray into the air inlet or flue terminal or onto the surface of the water heater.
 - Wait a few minutes to allow any aerosol gases to dissipate before opening the cold water isolation valve at the inlet to the water heater.

MAJOR SERVICE EVERY FIVE YEARS

For safe and efficient operation, it is recommended a major service be conducted on the water heater every five years.

⚠ Warning: Servicing of a water heater must only be carried out by qualified personnel. Phone Rheem Service or their nearest Accredited Service Agent.

Note: The major service and routine replacement of any components, if required, are not included in the Rheem warranty. A charge will be made for this work. Only genuine replacement parts should be used on this water heater.

The major service includes the following actions:

- Remove and clean cold water inlet strainer.
- Check and if necessary adjust the gas pressure.
- Check the operation of and clean the burner and heat exchanger.
- Visually check the unit for any potential problems.
- Inspect all connections.

TO TURN OFF THE WATER HEATER

If it is necessary to turn off the water heater:

- Close the gas isolation valve at the inlet to the water heater.
- Close the cold water isolation valve at the inlet to the water heater.

Note: This water heater does not have a frost protection system. If there is a risk of freezing conditions, the water heater must be drained, otherwise damage could result. Refer [“No Frost Protection”](#) on page 10 and [“Draining the Water Heater”](#) on page 12.

TO TURN ON THE WATER HEATER

- Screw in the drain plugs at the cold water inlet and hot water outlet of the water heater if the water heater has been drained.
- Open all of the hot taps in the house (don't forget the shower).
- Open the cold water isolation valve fully at the inlet to the water heater.
Air will be forced out of the taps.
- Close each tap as water flows freely from it.
- Open the gas isolation valve fully at the inlet to the water heater.

The water heater will operate automatically when you open a hot tap.

DRAINING THE WATER HEATER

- Turn off the water heater. Refer to [“Turn Off The Water Heater”](#) on page 12.
- Open a hot tap (preferably the shower outlet).
- Unscrew the two drain plugs, one each at the cold water inlet and hot water outlet, on the underside of the water heater.
Water will drain from the water heater.
- When water stops flowing from the water heater, close the hot tap.

Note: It is recommended not to screw the drain plugs back in, until the water heater is to be turned on again.

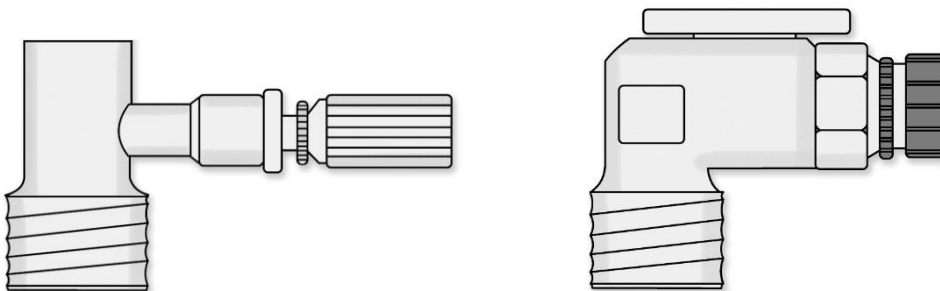

GOING ON HOLIDAYS

If you are going on holidays, it is not necessary to turn the water heater off. If it is necessary to turn off the water heater, refer to [“To Turn Off The Water Heater”](#) on page 12.

VICTORIAN CUSTOMERS

Notice to Victorian Customers from the Victorian Building Authority. This water heater must be installed by a licensed person as required by the Victorian Building Act 1993.

Only a licensed person will give you a Compliance Certificate, showing that the work complies with all the relevant Standards. Only a licensed person will have insurance protecting their workmanship for 6 years. Make sure you use a licensed person to install this water heater and ask for your Compliance Certificate.

DOES THE WATER CHEMISTRY AFFECT THE WATER HEATER?

The water heater is suitable for most public water supplies, however some water chemistries may have detrimental effects on the water heater, its components and fittings. Refer to [“Water Supplies”](#) on page 14.

If you are in a known harsh water area or you are not sure of your water chemistry, have your water checked against the conditions [described on page 14](#).

HOW LONG WILL THE WATER HEATER LAST?

The water heater is supported by a manufacturer’s warranty ([refer to page 4](#)). There are a number of factors that will affect the length of service the water heater will provide. These include but are not limited to the water chemistry, the water pressure, the water temperature (inlet and outlet) and the water usage pattern. Refer to [“Precautions”](#) on page 10.

WATER SUPPLIES

This water heater must be installed in accordance with this advice to be covered by the Rheem warranty.

This water heater is manufactured to suit the water conditions of most public reticulated water supplies. However, there are some known water chemistries which can have detrimental effects on the water heater and its operation and / or life expectancy. If you are unsure of your water chemistry, you may be able to obtain information from your local water supply authority. This water heater should only be connected to a water supply which complies with these guidelines for the Rheem warranty to apply.

CHANGE OF WATER SUPPLY

The changing or alternating from one water supply to another can have a detrimental effect on the operation and / or life expectation of a heat exchanger in an instantaneous water heater.

Where there is a changeover from one water supply to another, e.g. a rainwater tank supply, bore water supply, desalinated water supply, public reticulated water supply or water brought in from another supply, then water chemistry information should be sought from the supplier or it should be tested to ensure the water supply meets the requirements given in these guidelines for the Rheem warranty to apply.

SATURATION INDEX

The saturation index (SI) is used as a measure of the water's corrosive or scaling properties. The saturation index figures stated are calculated using a water temperature of 80°C.

In a corrosive water supply, the water can attack copper parts and cause them to fail. Where the saturation index is less than -1.0, the water is very corrosive and the Rheem warranty does not apply to a copper heat exchanger in an instantaneous water heater.

In a scaling water supply calcium carbonate is deposited out of the water onto any hot metallic surface. Where the saturation index exceeds +0.80, the Rheem warranty does not apply to a copper heat exchanger in an instantaneous water heater.

Water which is scaling may be treated with a water softening device to reduce the saturation index of the water.

Refer to the [Saturation Index chart](#) on page 14.

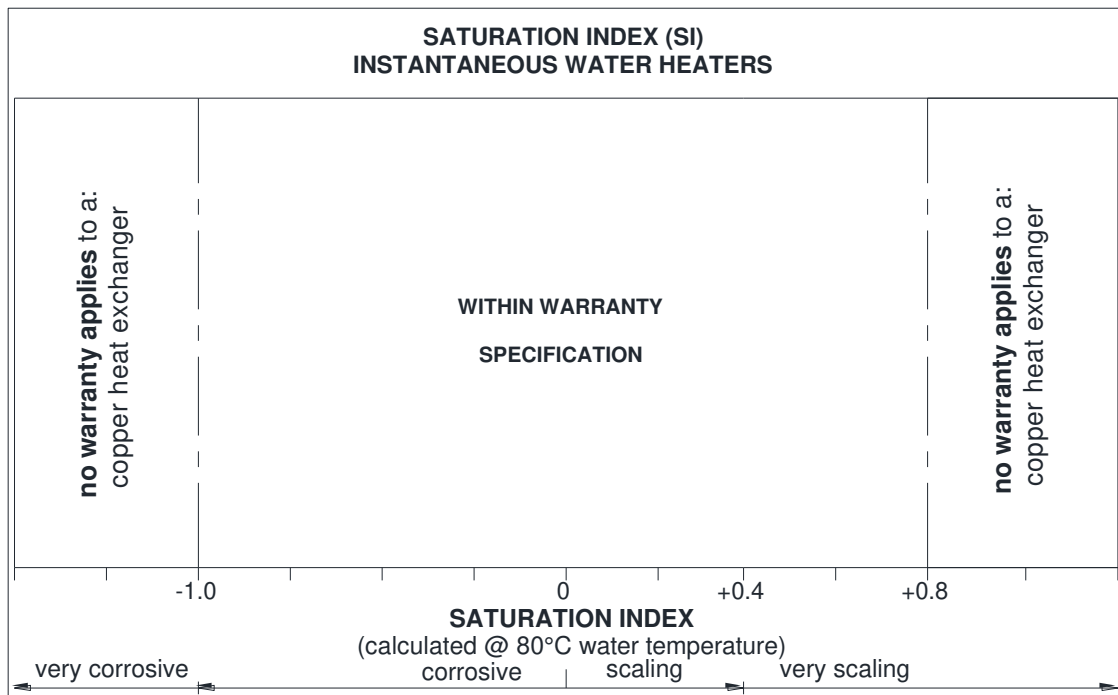

SAVE A SERVICE CALL

Check the items below before making a service call. You will be charged for attending to any condition or fault, which is not related to manufacture or failure of a part (refer to “[Terms of the Rheem Warranty](#)” on page 4).

COLD WATER FROM THE HOT TAP

- Close the hot tap, wait 10 seconds and open the hot tap again.
- Is the hot tap open enough or is the water flow rate too low?

The burners will not light if the flow rate is less than 3.0 L / min.

The cold water inlet strainer may require cleaning.

- Is the isolation valve in the gas line open?
- Is there a gas supply to the rest of the house?

Try lighting another gas appliance.

- Has the gas line been purged of air after installation?

Refer to a plumber.

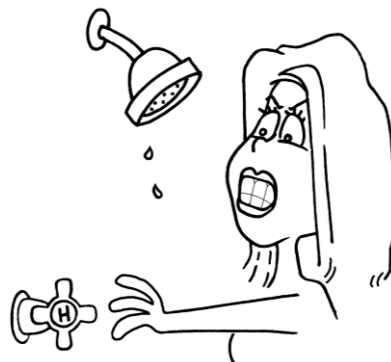

WATER IS NOT HOT ENOUGH

- Is the seasonal water flow adjustment valve set to an inappropriate setting?

Set to the “Winter” position.

WATER FLOW OR TEMPERATURE FLUCTUATES

More than one tap in use at the same time may cause a decrease in the hot water flow or a fluctuation in hot water temperature from the taps.

- Are there several hot taps open, or are appliances such as a dishwasher or washing machine, in use at the same time?

Ensure only one or two hot taps or appliances are on at the one time.

- Check the flow of hot water from each tap to see if one or more outlets are using more water than you think.

Have a plumber install a flow control valve to each shower outlet, basin and sink to reduce water usage, flow and temperature fluctuation.

- Do you have the correct size water heater for your requirements?

The sizing guide in the sales literature and on the Rheem website (www.rheem.com.au) suggests average sizes that may be needed.

REDUCED HOT WATER FLOW WHEN HEAT EXCHANGER IS COLD

At a cold start-up, i.e. when the water heater has not operated for some time (which is most often first thing in the morning), the initial flow of hot water may be reduced for a period of 5-10 seconds while the heat exchanger warms up. **This is both an energy and water saving feature of this water heater.** Once the heat exchanger has warmed up the hot water flow will increase and remain at normal flow levels. This feature will only occur at a cold start-up and not when the heat exchanger is already warm from a recent use of hot water.

NO WATER FROM THE HOT TAP

No flow of water from the hot tap may indicate a restriction in or failure of the cold water supply to the water heater. Check for water flow at other taps and that the cold water isolation valve ([refer to page 23](#)) is fully open.

CLOUDS OF WHITE 'VAPOUR' FROM THE FLUE TERMINAL

During the heating cycle, it is not unusual to see water vapour clouds steaming from the flue terminal, particularly on cold or humid days. This is normal operation of the water heater.

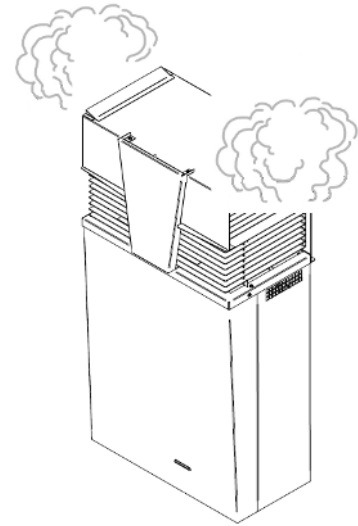

PRESSURE RELIEF VALVE DISCHARGING

A pressure relief valve is incorporated into the water heater controls. This valve protects the water heater, by allowing water to escape, in the event of excessive pressure build-up in the waterways.

- **Normal operation**
A small volume of water may discharge from the bottom of the water heater when a hot tap is suddenly closed.
- **Continuous dribble**
A continuous dribble may indicate the water supply pressure is above the design pressure for the water heater. If so, a pressure limiting valve must be installed on the cold water supply pipe to the water heater (refer to "Mains Water Supply" on page 18).

ERROR CODE

The water heater provides a diagnostic error code in the event of an interruption to its operation. The error code is displayed on the indication window on the front of the water heater as a flashing red LED whilst the hot tap is open. If the red LED is flashing:

- Close the hot tap.
- Check the gas isolation valve at the gas inlet to the water heater is fully open.
- Wait 5 minutes, then open a hot tap.

If the error code persists, count the number of flashes and then turn off the hot tap. Phone Rheem Service or their nearest Accredited Service Agent to arrange for inspection.

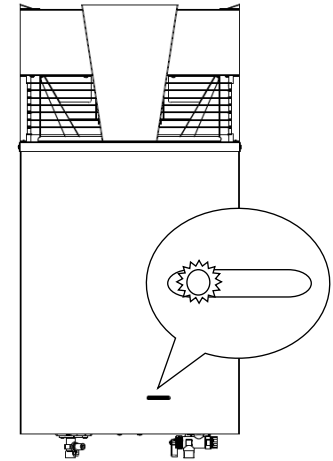

HIGHER THAN EXPECTED GAS BILLS

Should you at any time, feel your gas bill is higher than expected, we suggest you check the following points:

- Is one outlet (especially the shower) using more hot water than you think?
Carefully review the family's hot water usage. Inexpensive flow control valves can be easily fitted to the shower outlets to reduce water usage.
- Has there been an increase in hot water usage?
An increase in hot water usage will result in an increase in water heater operation.
- Has your water heating tariff rate been increased by your gas retailer since your previous bill?



IF YOU HAVE CHECKED ALL THE FOREGOING AND STILL BELIEVE YOU NEED ASSISTANCE, PHONE RHEEM SERVICE OR THEIR NEAREST ACCREDITED SERVICE AGENT.

INSTALLATION – WATER HEATER

**THIS WATER HEATER IS FOR OUTDOOR INSTALLATION ONLY.
THIS WATER HEATER IS NOT SUITABLE FOR POOL HEATING.
Check the water heater is suitable for the gas type available.
(refer to the rating label on the water heater)**

INSTALLATION STANDARDS

The water heater must be installed:

- by a qualified person, and
- in accordance with the installation instructions, and
- in compliance with the Plumbing Code of Australia (PCA), Standards AS/NZS 3500.4 and AS/NZS 5601.1, and all local codes and regulatory authority requirements,

⚠ Warning: 834 series – This water heater may deliver water at high temperature. Refer to the Plumbing Code of Australia, local requirements and these installation instructions to determine if additional delivery temperature control is required. Refer to [“Hot Water Delivery”](#) on page 20.

All packaging materials must be removed from the water heater prior to its installation.

WATER HEATER APPLICATION

This water heater is designed for use in a single family domestic dwelling for the purpose of heating potable water. Its use in an application other than this may shorten its life.

This water heater is not suitable for pool heating, or as part of hot water circulation flow and return system, or as an in-series booster for a solar water heater, and **MUST NOT** be used for these applications.

If this water heater is to be used where an uninterrupted hot water supply is necessary for the application or business, then there should be back-up redundancy within the hot water system design. This should ensure the continuity of hot water supply in the event that this water heater was to become inoperable for any reason. We recommend you provide advice to the system owner about their needs and building back-up redundancy into the hot water supply system.

WATER HEATER LOCATION

The water heater is suitable for outdoor installation only and should be installed close to the most frequently used outlet and its position chosen with safety and service in mind. Make sure people (particularly children) will not touch the flue terminal. The flue terminal and air inlet must be clear of obstructions and shrubbery.

Clearance must be allowed for servicing of the water heater. The water heater must be accessible without the use of a ladder or scaffold. Make sure the entire front panel can be removed for service. You must be able to read the information on the rating plate. Remember you may have to take the entire water heater out later for servicing.



This water heater must be installed vertically upright with the water and gas connections on the underside, pointing toward the ground. The back of the water heater can be either against a wall or supported by a frame.

If the water heater is fitted on a wall of combustible material, the wall must be protected by a fire resistant heat shield. Refer to [“Heat Shield”](#) on page 19 for the size and location of the heat shield.

Note: The water heater must be well secured to the wall or frame using two fasteners at the top and one fastener at the bottom of the unit (refer to page 22 for [mounting hole positions](#) and weight of the water heater). Use the screws provided only if they are suitable for the wall or frame type. Otherwise select and use alternative fasteners suitable for the application. The fasteners must be capable of bearing the full weight of the water heater so it may not work loose nor impose any load on the gas and water pipe work connected to the water heater. Refer to the fastener manufacturer’s information and recommendations for the type of fastener to use for the wall or frame type and load bearing requirements.

The water heater must not be installed in an area with a corrosive atmosphere where chemicals are stored or where aerosol propellants are released. Remember the air may be safe to breathe, but when it goes through a flame, chemical changes take place which may attack the water heater.

A secondary flue is not required. The water heater must not be installed indoors or in a confined space.

The water heater must be located to ensure that the location of the flue terminal complies with the requirements of AS/NZS 5601.1. As a guide the following requirements are extracted from the Gas Installations Standard. The distances are measured along the wall behind the water heater.

- At least 500 mm between the top of the flue terminal and the eaves.
- At least 500 mm between the flue terminal and the edge of any opening into the building, such as an openable door or window, measured horizontally*.
- At least 1000 mm between the top of the flue terminal and the edge of any opening into the building, such as an openable window, measured vertically.
- At least 500 mm between the flue terminal and a return wall or external corner, measured horizontally*.
- At least 500 mm between the flue terminal and any opening into a building, in the direction of the flue discharge.

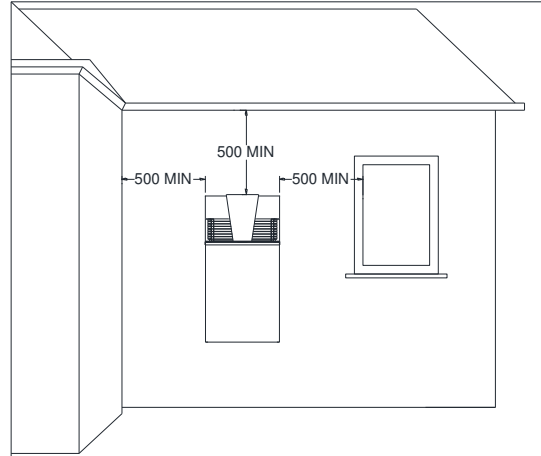

- At least 500 mm between the flue terminal and a fence, wall or other obstruction, in the direction of the flue discharge.

Note: * If these horizontal distances cannot be achieved, AS/NZS 5601.1 states an equivalent horizontal distance measured diagonally from the nearest discharge point of the flue terminal to the opening may be deemed to comply. Check with the local regulator.

MAINS WATER SUPPLY

Where the mains water supply pressure exceeds that shown in the table below, an approved pressure limiting valve that does not have non-return valve characteristics (such as an RMC PSL series valve) is required and should be fitted as shown in the installation diagram (refer to page 23).

Model	012	016
Pressure relief valve setting	1000 kPa	1000 kPa
Maximum mains supply pressure	800 kPa	800 kPa
Minimum mains supply working pressure *	120 kPa	140 kPa

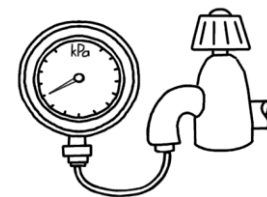

* minimum water supply working pressure required to achieve the rated flow and performance

Notes

- It is not recommended to install this water heater with a low pressure water supply.
- A minimum water supply working pressure of 140 kPa for 016 models and 120 kPa is required for 012 models, i.e. whilst water is flowing through the water heater, is required to achieve the rated flow and performance of the water heater.
- If sludge or foreign matter is present in the water supply, it is recommended a suitable filter be incorporated in the cold water line to the water heater.
- This water heater is not suitable for connection to bore water or spring water unless a water treatment device is fitted.
- Refer to “Water Supplies” on page 14 for further information on water chemistry.

HEAT SHIELD

If the water heater is installed on a wall of combustible material, the wall must be protected by a heat shield. The minimum dimensions of the heat shield are 850 mm wide x 400 mm high. If a metal plate is used, its minimum thickness must be 0.8 mm and when installed must provide air gaps on both the front face between the flue terminal and heat shield and on the rear face between the wall and the heat shield. A 9 mm air gap is recommended between the rear face of the heat shield and the wall surface to enable natural convective cooling of the wall surface.

Refer to the [Heat Shield Dimensions and Position](#) diagram on page 19.

A heat shield is available from Rheem (PN 299880) as an accessory.

Notes

- If the installation is on an uneven wall surface, ensure a metal plate heat shield is NOT in contact with the wall surface. In some situations, it may be necessary to fix a backing plate onto the wall to even out the wall surface. The heat shield would then mount to the backing plate.
- Ensure the air gap between the heat shield and the wall surface or backing plate (if one is installed) is kept clear, allowing natural ventilation.

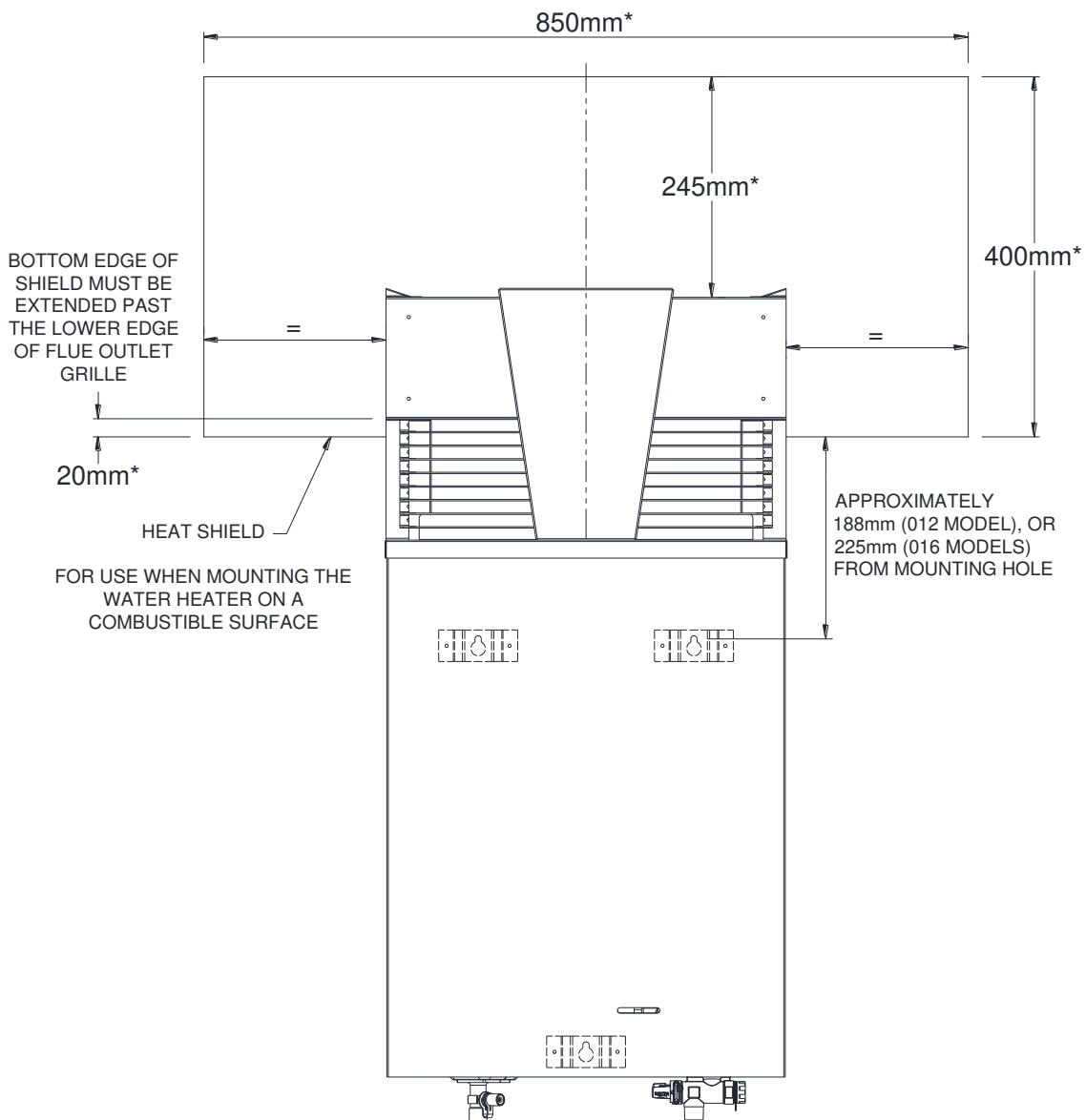

NOTE: * MINIMUM DIMENSIONS

Heat Shield Dimensions and Position

INSTALLATION WITHIN A COVERED AREA

The water heater must be located such that the installation meets the requirements of AS/NZS 5601.1. There must be sufficient ventilation so the water heater has an adequate supply of combustion air and the flue products are dispersed safely. It is the licensed installer’s responsibility to ensure the installation complies with the relevant sections of the Gas installations Standard.

Installation of this water heater is permitted within a covered area open on at least two sides, if its flue terminal is located to ensure a free flow of air across it is achieved. The installer must determine if the flue gases can be dispersed effectively and not cause any nuisance.

This water heater is not suitable for installation within a covered area open on one side only.

HOT WATER DELIVERY

This water heater can deliver hot water at temperatures up to 60°C, which can cause scalding. Water at this temperature may be plumbed to fixtures where water hotter than 50°C is allowed, such as the kitchen and laundry.

The installing plumber may have a legal obligation to ensure the installation of this water heater meets the delivery water temperature requirements of the Plumbing Code of Australia so that scalding water temperatures are not delivered to a bathroom, ensuite or other ablution or public area.

It is necessary and we recommend that a temperature limiting device be fitted between an 834 series water heater and the hot water outlets in any ablution and public areas such as a bathroom, ensuite or public amenities, to reduce the risk of scalding. The temperature limiting device must be of a type suitable for use with an instantaneous gas water heater. Refer to the manufacturer’s specifications of the temperature limiting device.

Where a temperature limiting device is installed adjacent to the water heater, the cold water line to the temperature limiting device can be branched off the cold water line either before or after the isolation valve and pressure limiting valve to the water heater.

If a pressure limiting valve is installed on the cold water line to the water heater and the cold water line to a temperature limiting device branches off before this valve or from another cold water line in the premises, then a pressure limiting valve of an equal pressure setting may be required prior to the temperature limiting device.

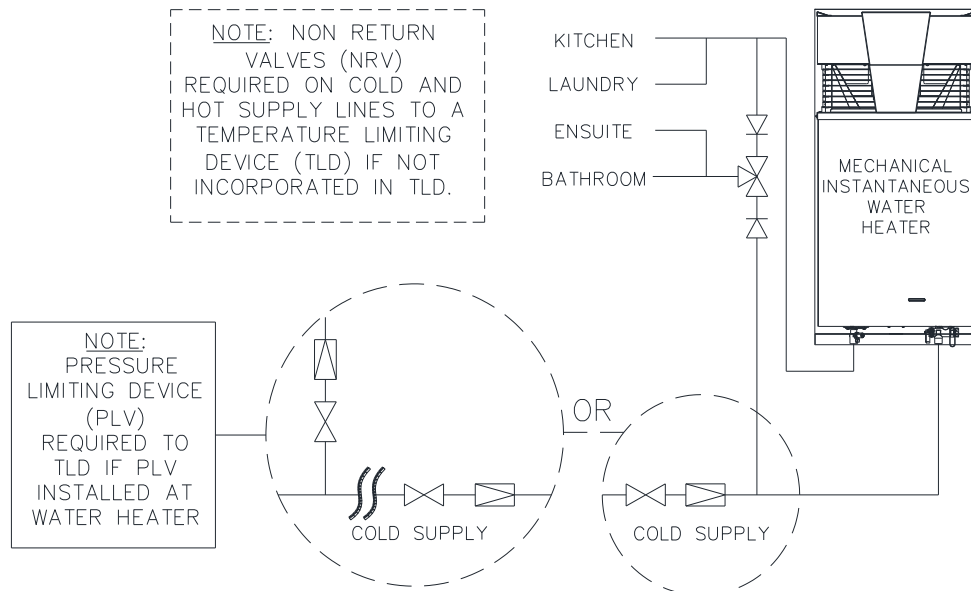

Two Temperature Zones Using a Temperature Limiting Device

NO FROST PROTECTION

The water heater is **NOT** fitted with a frost protection system. If there is a risk of freezing, then it is necessary to drain the water heater (refer to “[Draining the Water Heater](#)” on page 30). Damage caused by freezing is not covered by the Rheem warranty (refer to “[Terms of the Rheem Warranty](#)” on page 4).

Damage to the water heater caused by freezing of the pipe work to or from the water heater is not covered under the Rheem warranty. Refer to AS/NZS 3500.4 for precautions to be taken for installations in frost prone areas.

The cold water line to the water heater must be insulated with suitable thickness insulation if freezing conditions are likely to occur. The insulation must be fitted to the underside of the water heater and be weatherproof and UV resistant if exposed.

REDUCING HEAT LOSSES

The cold water line to and hot water line from the water heater must be insulated in accordance with the requirements of AS/NZS 3500.4 to. The insulation must be weatherproof and UV resistant if exposed. The insulation must be fitted up to the connections on the underside of the water heater.

TYPICAL INSTALLATION – OUTDOOR LOCATION

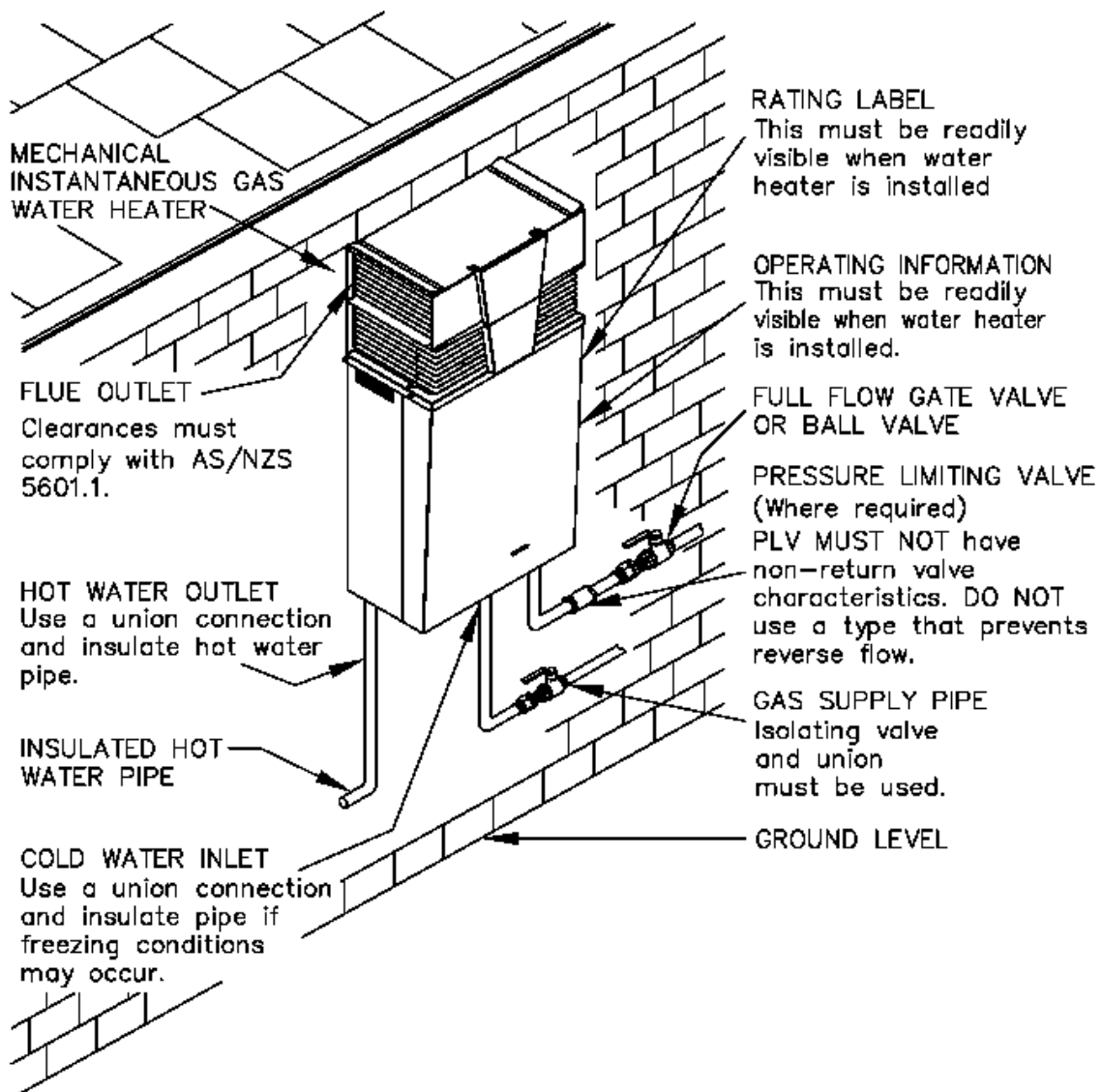

DIMENSIONS AND TECHNICAL DATA

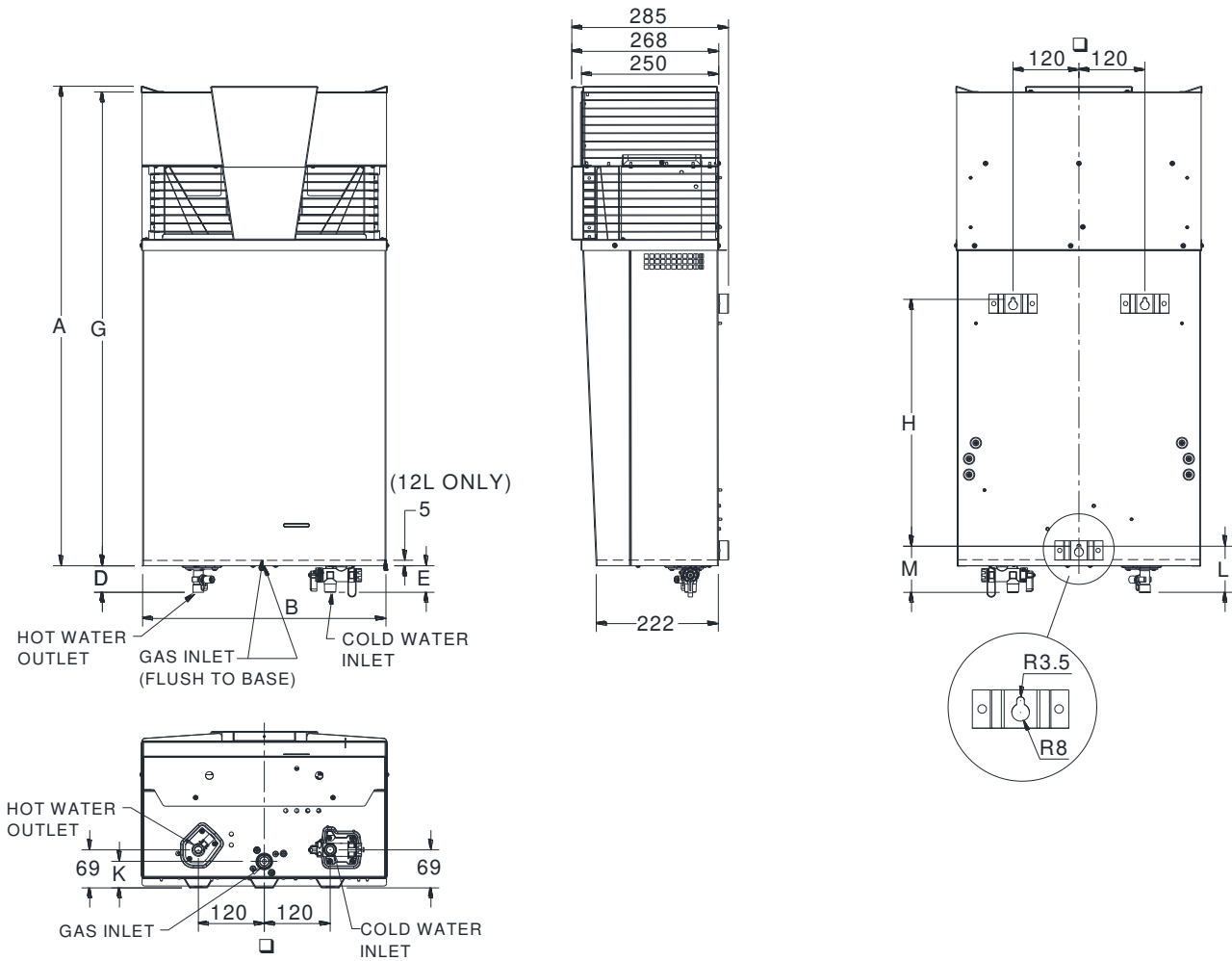

Model		834012	834016
Gas type suffix		N0, P0	N0, P0
Water heating capacity (@ 40°C rise)	litres / min	7.3	9.8
Nominal capacity (@ 25°C rise)	litres / min	12	16
Mass Empty (unpacked)	kg	21	25

Dimensions		A	B	D	E	G	H	K	L	M
834 012	mm	840	388	45	45	830	465	55	70	70
834 016	mm	875	443	50	50	866	451	48	84	84

Gas Details	Hourly Gas Consumption (MJ)		Minimum Gas Pressure (kPa)	Test Point Gas Pressure (kPa)				Maximum Gas Pressure (kPa)	Injector Size (mm)		Pilot Injector (mm)
	012	016		minimum		maximum			012	016	
Size	012	016	012, 016	012	016	012	016	012, 016	012	016	012, 016
Natural	99	128	1.13	0.080	0.088	0.72	0.74	3.50	14 x Ø 1.30	18 x Ø 1.30	Ø 0.60
Propane	96	125	2.75	0.210	0.210	1.85	1.85	3.50	14 x Ø 0.80	18 x Ø 0.80	Ø 0.35

Model numbers: N = Natural, P = Propane, to denote gas type.
 Letter N or P is included in the model number, e.g. 834016N0.
 Character following gas type letter, 0 = no frost protection.
 Technical data is subject to change.

CONNECTIONS – PLUMBING

All plumbing work must be carried out by a qualified person and in compliance with the Standard AS/NZS 3500.4 and all local codes and regulatory authority requirements.

All gas work must be carried out by a qualified person and in compliance with the Standard AS/NZS 5601.1, all local codes and regulatory authority requirements.

Note: The water heater is fitted with a gas pressure regulator preset to the gas type of the water heater. There is no need to install an additional gas pressure regulator unless the gas supply pressure exceeds 3.5 kPa.

CONNECTION SIZES

Model	834 012	834 016
• Hot water connection	R 1/2	R 1/2
• Cold water connection	R 1/2	R 1/2
• Gas inlet connection	Rp 3/4	Rp 3/4

WATER INLET AND OUTLET

All pipe work must be cleared of foreign matter before connection and purged before attempting to operate the water heater. All olive compression fittings must use brass or copper olives. Use an approved thread sealant such as Teflon tape on all threaded joints. Only use sufficient thread sealant to seal a joint. Refer to the sealant manufacturer's guidelines for how much and where to use.

Warning: Sealant must not be allowed in the waterways of pipe work or fittings. Excess sealant may be carried into the water heater where it will damage components and block the internal filters. This damage to components or blockage of filters is not covered by the Rheem warranty and a service rectification fee will be charged.

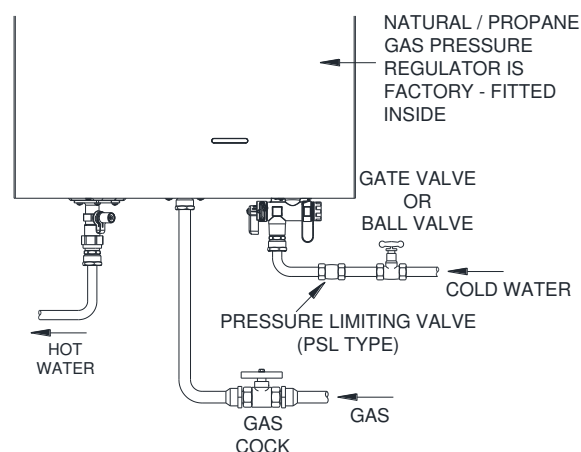

**Gas Water Heater
Cold and Hot Water and Gas Connection Details**

A full flow gate valve or ball valve must be installed on the cold water line to the water heater. **A non-return valve or stop tap must not be installed.** An acceptable arrangement is shown in the diagram. Refer also to [“Hot Water Delivery”](#) on page 20 and to [“Mains Water Supply”](#) on page 18.

A disconnection union must always be provided at the cold water inlet and hot water outlet on the water heater to allow for disconnection of the water heater.

Insulation used on the cold and hot water lines must extend up to the cold water inlet and hot water outlet of the water heater.

This water heater is intended to be permanently connected to the water mains and not connected by a hose-set. A braided flexible hose or semi-flexible connector may be used for connection to the water heater, where permitted by AS/NZS 3500.4.

Notes

- It is essential all pipe connections be correctly aligned, otherwise component connections within the water heater may be strained and / or components themselves misaligned. It is recommended also, wherever possible, pipe connections be made at the water heater first and final pipe runs be made in soft copper pipe to allow some adjustment for misalignment.
- Use the spanner flats on the water heater fittings and take care to avoid twisting the water inlet and outlet pipes inside the jacket.

PIPE SIZES

The pipe sizing for hot water supply systems should be carried out by persons competent to do so, choosing the most suitable pipe size to ensure adequate flow for each individual application. Reference to the technical specifications of the water heater and local regulatory authority requirements must be made.

To achieve true mains pressure operation, the cold water line to the water heater should be the same size or bigger than the hot water line from the water heater.

The minimum recommended cold pipe and hot pipe size is DN15.

GAS INLET

The gas connection is made at the underside of the water heater. The pipe work must be cleared of foreign matter before connection and purged before attempting to operate the water heater. An isolation valve and disconnection union must be installed to allow servicing and removal of the water heater (refer to the [diagram on page 23](#)).

Note: Refer to the Gas Installations Standard AS/NZS 5601.1 for the correct method of sizing the gas supply pipe to the water heater. The pipe size selection must take into account the high gas input of this water heater ([refer to table on page 22](#)) as well as all of the other gas appliances in the premises.

 **Warning:** Always isolate the water heater before pressure testing the gas supply system. Disconnect the water heater after the isolation valve to prevent the risk of serious damage to the gas control. The Rheem warranty does not cover damage of any nature resulting from failure to observe this precaution. Refer to rating label for gas types and pressures.

WIRING DIAGRAM

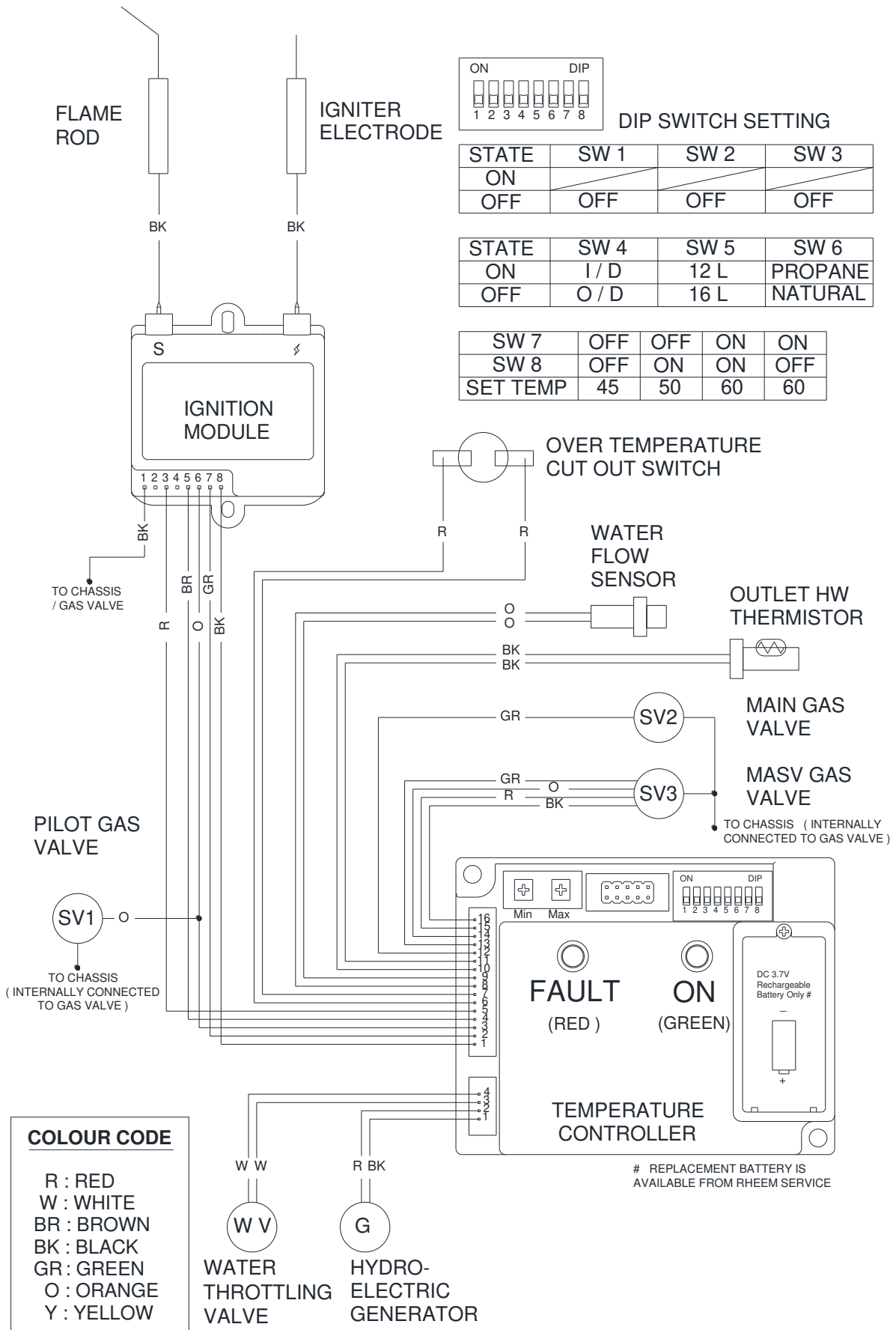

Wiring Diagram – 834 Series Water Heater

COMMISSIONING

All water heaters are tested and adjusted before dispatch from the factory, however further adjustments may become necessary because of local conditions.

TO TURN ON THE WATER HEATER

- Open all of the hot taps in the house (don't forget the shower).
- Open the cold water isolation valve fully at the inlet to the water heater.

Air will be forced out of the taps.

- Close each tap as water flows freely from it.
- Check the pipe work for leaks.
- Open the gas isolation valve fully.
- Check the gas pipe work for leaks.
- Open a hot tap.

The water heater will operate automatically.

- Check to ensure the flow from each connected hot tap is sufficient to operate the water heater.

The minimum operating flow rate for all models is 3.0 litres per minute.

- Check and if required adjust the preset outlet temperature setting of the water heater.

Refer to "[Preset Outlet Temperature Setting](#)" on page 29.

- Set the seasonal water flow adjustment valve (located at the underside of the water heater) to the "Summer" position.

Upon completion of the installation, it may be necessary to set the seasonal water flow adjustment valve to another more appropriate position to suit the time of the year and incoming cold water temperature.

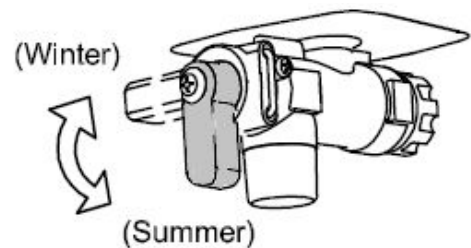

**water flow adjustment valve
(manual seasonal adjustment)**

To complete the installation, it is necessary to check the gas supply pressure at the inlet to the water heater (refer to "[Inlet Gas Pressure](#)" on page 26), the minimum test point pressure and the maximum test point pressure (refer to "[Burner Gas Pressure](#)" on page 28).

Explain to the householder or a responsible officer the functions and operation of the water heater.

⚠ Warning: Upon completion of the installation and commissioning of the water heater, leave this guide with the householder or a responsible officer. **DO NOT** leave this guide inside of the cover of the water heater, as it may interfere with the safe operation of the water heater or ignite when the water heater is turned on.

INLET GAS PRESSURE

IMPORTANT – CHECK the gas supply pressure at the inlet to the water heater with the water heater and all other gas burning appliances in the premises operating (burners alight). The minimum gas supply pressure is:

Natural Gas	1.13 kPa	Propane	2.75 kPa
-------------	----------	---------	----------

If this minimum cannot be achieved, it may indicate the meter or the gas line to the water heater is undersized. It is important to ensure that an adequate gas supply pressure is available to the water heater when other gas burning appliances, on the same gas supply, are operating.

Note: The maximum gas supply pressure shall not exceed 3.5 kPa. A gas pressure regulator shall be installed upstream to the water heater if the gas supply pressure may exceed this value. Damage to the water heater due to high gas pressure is not cover by the Rheem warranty.

Inlet Gas Pressure Test Point

To check the inlet gas pressure:

1. Close any hot taps and ensure the burner is not operating.
2. Close the gas isolation valve at the gas inlet to the water heater.
3. Remove the screws holding the front cover to the jacket.
4. Gently disengage the front panel and pull downward to remove from the water heater.
5. Locate the inlet gas pressure test point on the gas valve of the water heater.
 - Loosen the test point screw so that the test point orifice is not blocked.
 - Connect the manometer.
6. Open the gas isolation valve fully at the gas inlet to the water heater.
7. Turn on all other gas burning appliances in the house which are on the same gas supply.
8. Open a hot tap fully and ensure the burner is fully ignited.

It may be necessary to open a second tap to allow the water heater to operate at full capacity and enable the burners to fully ignite.

9. Observe the gas pressure reading on the manometer.

If the manometer reading is between the minimum and maximum inlet gas pressure ratings on the rating label, no adjustment is required.

If the manometer reading is below the minimum inlet gas pressure rating on the rating label, then either the gas pipe to the water heater is undersized and needs to be rectified or adjustment is required at the gas meter regulator. Check with the gas supply authority.

If the manometer reading is above the maximum inlet gas pressure rating on the rating label, then adjustment is required at the gas meter regulator. Check with the gas supply authority.

10. Close the hot tap.
11. Turn off the other gas burning appliances in the house.
12. Close the gas isolation valve at the inlet to the water heater.
13. Remove the manometer and tighten the test point screw.
14. Open the gas isolation valve fully at the gas inlet to the water heater.
15. Open a hot tap again so the burner ignites.
16. Test for gas leaks.
17. Close the hot tap.
18. Refit the front panel to the water heater.

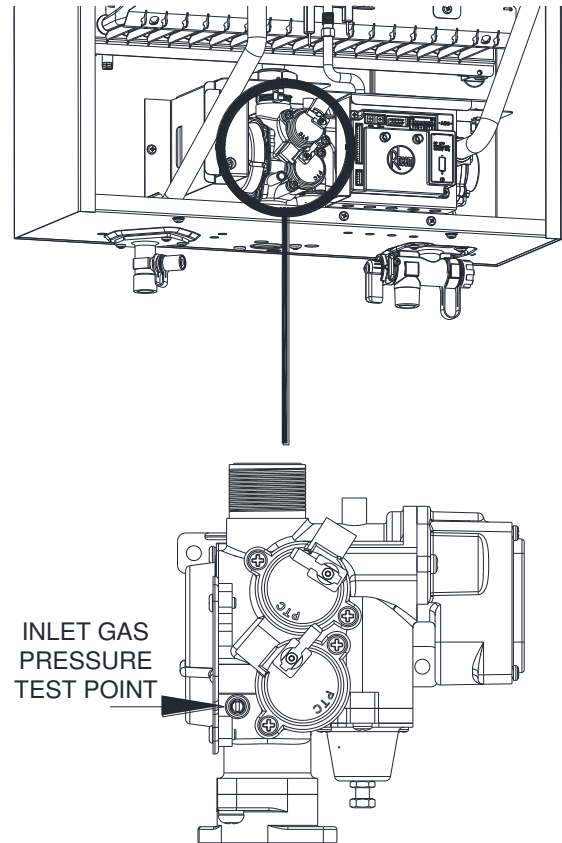

BURNER GAS PRESSURE

It is necessary to check the burner gas pressure at both the minimum and maximum operational settings. To check and if necessary adjust the operational gas pressures, the burner must be ignited and hot water must be flowing from a hot tap.

Checking and Adjusting Test Point Burner Gas Pressures

Refer to the rating label on the water heater for the minimum and maximum test point gas pressures.

1. Close any hot taps and ensure the burner is not operating.
2. Close the gas isolation valve at the gas inlet to the water heater.
3. Remove the screws holding the front panel to the jacket.
4. Gently disengage the front panel and pull downward to remove from the water heater.
5. Locate the burner gas pressure test point on the main burner manifold.
 - Remove the test point screw and washer from the test point orifice.
 - Connect the manometer.
6. Open the gas isolation valve fully at the gas inlet to the water heater.
7. Set dip switches 1, 2 and 3 to the “ON” (up) position.
8. Open a hot tap fully until the burner ignites.

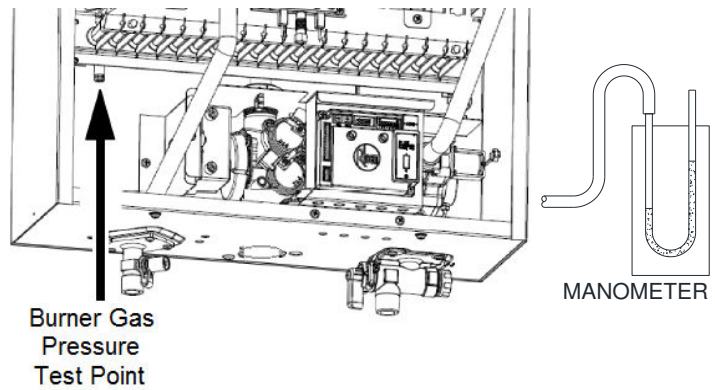

The burner will now operate on the minimum gas pressure setting.

9. Observe the gas pressure reading on the manometer and compare to the minimum test point gas pressure stated on the rating label.
10. If adjustment is required, using a phillips head screw driver turn the “MIN” dial anti-clockwise to increase the minimum burner gas pressure or clockwise to reduce the minimum burner gas pressure, whilst reading the gas pressure on the manometer.
11. When the minimum burner gas pressure is correctly adjusted, set dip switch 2 to the “OFF” (down) position.

The burner will now operate on the maximum gas pressure setting.

12. Observe the gas pressure reading on the manometer and compare to the maximum test point gas pressure stated on the rating label.

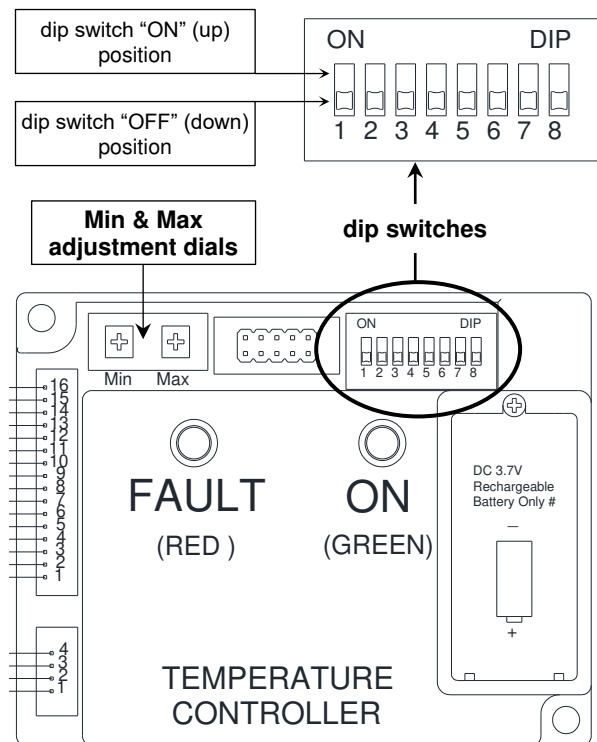

13. If adjustment is required, using a phillips head screw driver turn the “MAX” dial anti-clockwise to increase the maximum burner gas pressure or clockwise to reduce the maximum burner gas pressure, whilst reading the gas pressure on the manometer.
14. When the maximum burner gas pressure is correctly adjusted, **set the dip switch 1 to the “OFF” (down) position.**
15. Wait for 1 second, then **set dip switch 3 to the “OFF” (down) position.**
16. Turn off the hot water tap.

17. Close the gas isolation valve fully at the gas inlet to the water heater.
18. Remove the manometer and refit and tighten the test point screw and washer.
19. Turn on the gas isolation valve fully, open a hot water tap and check the burners ignite.
20. Check for gas leaks.
21. Turn off the hot water tap.
22. Refit the front panel to the water heater.

Notes

- Dip switch 3 must be set to the “OFF” (down) position after dip switches 1 and 2 are set to the “OFF” (down) position, otherwise the settings will not be saved.
- During the checking and adjusting of the burner gas pressures, the temperature control function is deactivated.
- For normal operation of the water heater, dip switches 1, 2 and 3 must be in the “OFF” (down) position.

PRESET OUTLET TEMPERATURE SETTING

The factory preset outlet temperature setting of the water heater is:

- 834 series 012, 016 models 60°C

It is usually not necessary to adjust the factory preset outlet temperature setting of the water heater, unless the customer has a particular requirement for this to be done.

Consideration must be given to the delivery temperature to any ablation and public areas such as a bathroom, ensuite or public amenities. Refer to “Hot Water Delivery” on page 20.

To Check Or Adjust The Preset Outlet Temperature Setting

The preset outlet temperature settings are:

- 834 series 45°C, 50°C, 60°C

SW 7	OFF	OFF	ON	ON
SW 8	OFF	ON	ON	OFF
SET TEMP	45	50	60	60

To check or adjust the preset outlet temperature setting:

1. Remove the screws holding the front panel to the jacket.
2. Gently disengage the front panel and pull downward to remove from the water heater.
3. Dip switches 7 and 8 on the Temperature Controller determine the preset outlet temperature setting of the water heater.

Adjust the dip switches to obtain the desired setting:

- 60°C – set dip switch 7 to the “ON” (up) position and dip switch 8 to either the “ON” (up) or “OFF” (down) position.
- 50°C– set dip switch 7 to the “OFF” (down) position and dip switch 8 to the “ON” (up) position.
- 45°C– set dip switch 7 to the “OFF” (down) position and dip switch 8 to the “OFF” (down) position.

4. Refit the front panel to the water heater.

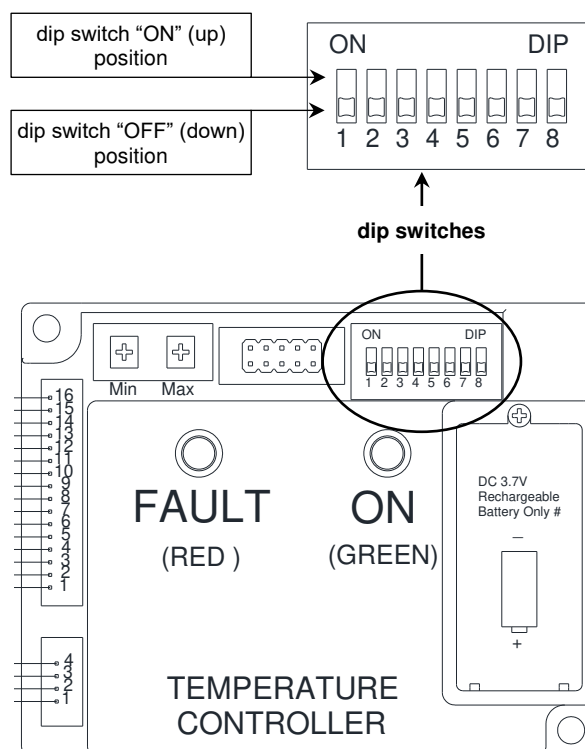

TO TURN OFF THE WATER HEATER

If it is necessary to turn off the water heater on completion of the installation, such as on a building site or where the premises is vacant, then:

- Close the gas isolation valve at the inlet to the water heater
- Close the cold water isolation valve at the inlet to the water heater.
- Drain the water heater if there is a risk of freezing conditions occurring (refer to [“Draining The Water Heater”](#) on page 30).

Notes

- The 834 series water heater does not have a frost protection system.
- Damage caused by freezing is not covered by the Rheem warranty (refer to [“Terms of the Rheem Warranty”](#) on page 4).

DRAINING THE WATER HEATER

To drain the water heater:

- Turn off the water heater (refer to [“Turn Off The Water Heater”](#) on page 30).
- Open a hot tap (preferably the shower outlet).
- Unscrew the two drain plugs, one each at the cold water inlet and hot water outlet, on the underside of the water heater.

Water will drain from the water heater.

- When water stops flowing from the water heater, close the hot tap.

Note: It is recommended not to screw the drain plugs back in, until the water heater is to be turned on again.

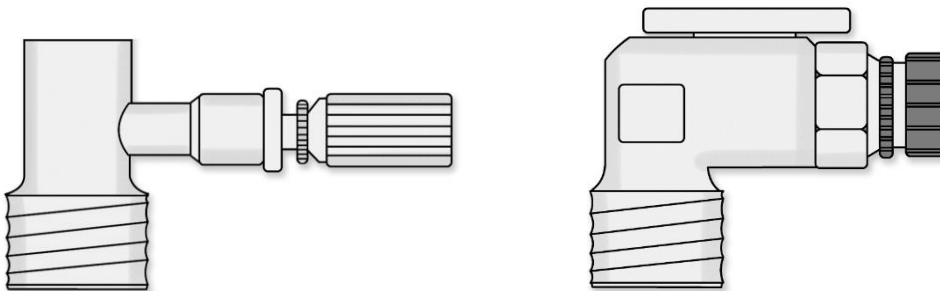

This page is intentionally blank.

