

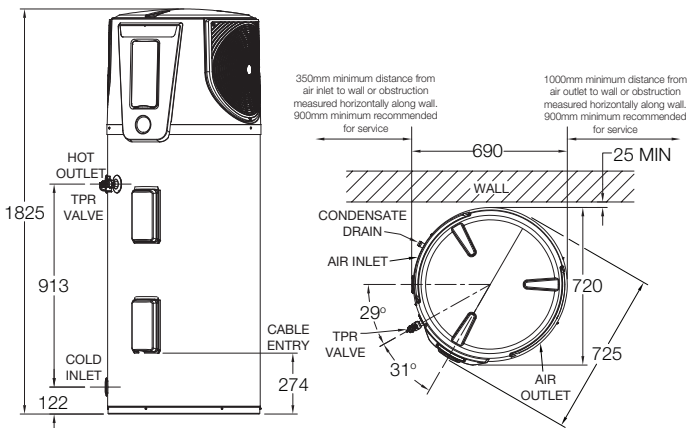

### Features & Benefits

- Advanced wrap around microchannel heating technology for uniform and faster water heating
- Suitable for harsh water and cold climates with an operating range from -5°C to 43°C <sup>6,7</sup>
- High recovery rate
- 2.4kW back-up element
- User-friendly touch screen LED display
- Eligible for Government Incentives
- 7 year cylinder warranty<sup>1</sup>



MODEL	551270
Storage Capacity (L)	270
Element Rating (kW)	2.4
Relief Valve Pressure (kPa)	1000
Expansion Control Valve (kPa)	850
Max Water Supply Pressure:	
with ECV (kPa)	680
without ECV (kPa)	800
Water Connections	Rp <sup>3</sup> / <sub>4</sub>
Approx. Weight (Empty) kg	135



Scan code for details & installation instructions



Conditions apply:

- <sup>1</sup> See the Rheem warranty in the product's Owner's Guide or view product warranties at [www.rheem.com.au/warranty](http://www.rheem.com.au/warranty)
- <sup>2</sup> Up to 42% lighter than comparable Rheem vitreous enamel water heater models of the same capacity.
- <sup>3</sup> 60°C and higher temperature models and some applications require a tempering valve in accordance with AS 3500.4.
- <sup>4</sup> Frost protection to 400m altitude above sea level
- <sup>5</sup> Eligibility criteria apply.
- <sup>6</sup> The specified -5°C to 43°C temperature range is the operational range of the heat pump. The electric element activates when the ambient air temperature is outside this range and heating of the water is required.
- <sup>7</sup> Warranty limits regarding water chemistry. Harsh water regions – the Rheem warranty may not apply if the water heater is connected to a water supply which has a Total Dissolved Solids content >2500mg/L; is scaling with a Saturation Index >+0.8, or; is corrosive with a Saturation Index <-1.0.